

- Table frame design features incorporate a nontip, nontrip & walk-through design.
- The one-piece welded construction frames are fabricated from 1-1/4" sch. 40 pipe (1.66 O.D.).
- Cross braces are 1" schedule 40 pipe.
- All pipe and tubing conforms to ASTM A513-94 and all steel components conform to ASTM-A569.
- Center, table and seat brackets are 1/8" (12 ga.) steel.
- All welds are continuous MIG welds for strength
- Assembly fasteners are 3/8" dia. galvanized steel carriage bolts.
- Lumber, 2" x 10" treated #1 grade southern yellow pine, is predrilled and has 3/8" rounded corners.
- All exposed corners are chamfered for safety.

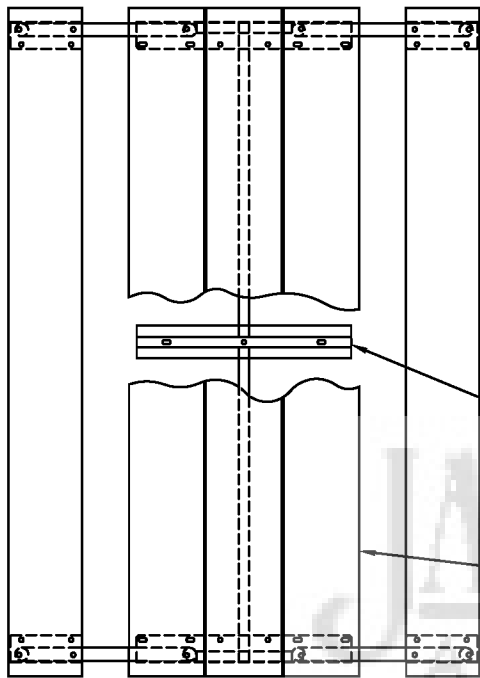

JAMESTOWN  
ADVANCED  
PRODUCTS  
CORPORATION

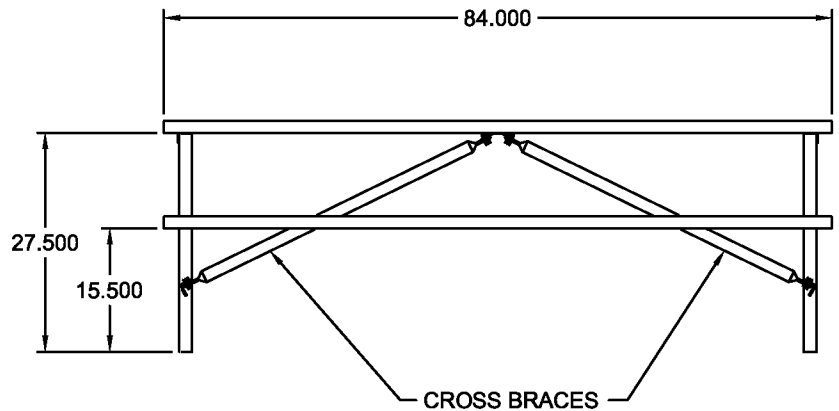
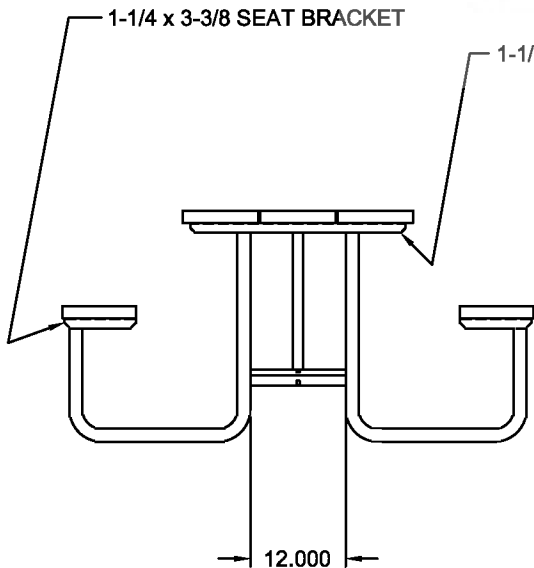

CUSTOMER APPROVAL :

DATE :

**JAMESTOWN**  
ADVANCED  
PRODUCTS  
CORPORATION

THIS DRAWING, WHICH CONTAINS PROPRIETARY INFORMATION, IS THE PROPERTY OF JAMESTOWN ADVANCED PRODUCTS CORPORATION. IT SHALL NOT BE REPRODUCED IN ANY MANNER NOR DISCLOSED TO THIRD PARTIES WITHOUT WRITTEN PERMISSION OF JAMESTOWN ADVANCED PRODUCTS CORPORATION.

DATE : 5-10-02

PRODUCT PART NUMBER : 11137-11S

REV. NO.

PRODUCT DESCRIPTION :

7' PICNIC TABLE

2855 GIRTS ROAD  
JAMESTOWN, NY 14701

PHONE 800-452-0639 -- FAX 716-483-5398 -- WWW.JAMESTOWNADVANCED.COM