

- Table frame design features incorporate a nontip, nontrip & walk-through design.
- The one-piece welded construction frames are fabricated using continuous MIG welds for strength.
- All pipe and tubing conform to ASTM A513-94, and all steel components conform to ASTM-A569.
- All cross braces are 1" schedule 40 pipe (.133" thk. wall).
- Center brackets are all 1/8" thk. (12 ga.) steel. Table and seat brackets are 1/8" thk. (12 ga.) steel for P/N's 11137, 11138 and 11139, and 3/16" thk. (7 ga.) steel for P/N 11135.
- Assembly fasteners are 3/8" dia. galvanized steel carriage bolts.
- All exposed corners are chamfered for safety.
- Approximate weights of tables including plastisol:
 - P/N 11135 = 260 lbs
 - P/N 11137 = 230 lbs
 - P/N 11138 = 215 lbs
 - P/N 11139 = 210 lbs

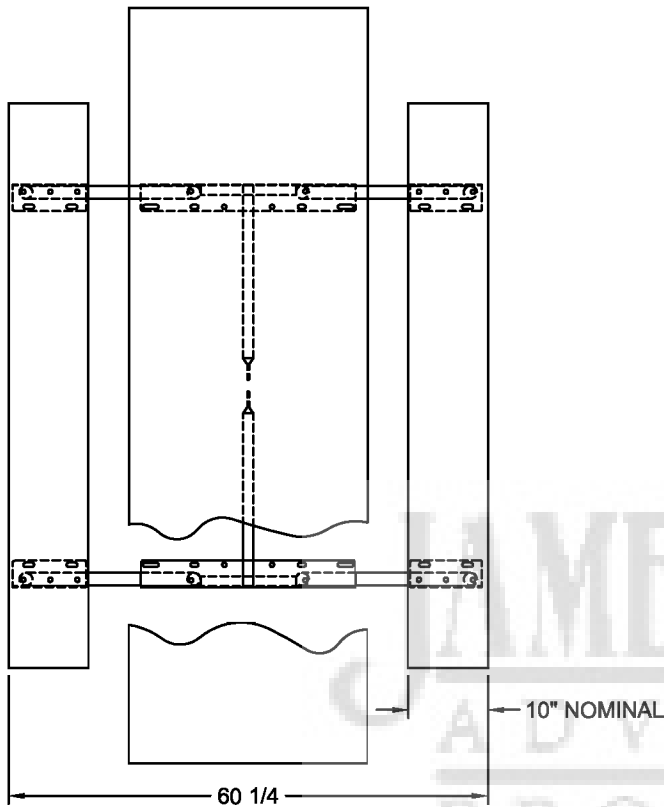

JAMESTOWN
ADVANCED
PRODUCTS
CORPORATION

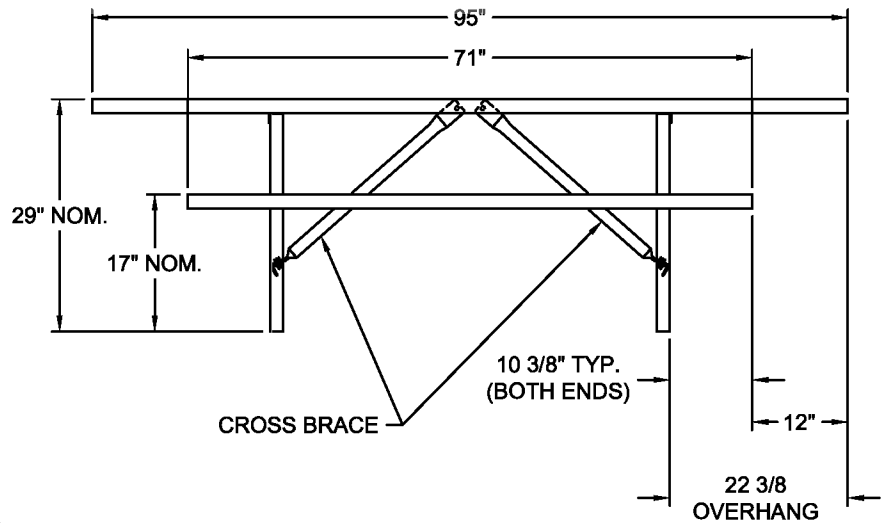
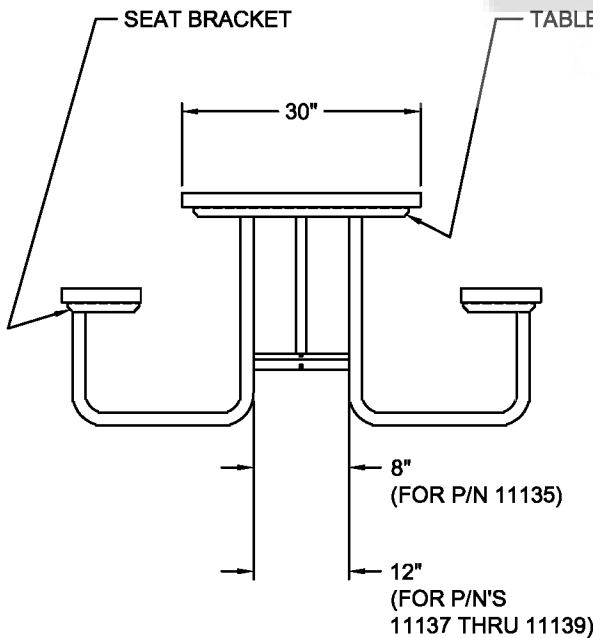

CUSTOMER APPROVAL :

DATE :

JAMESTOWN
ADVANCED
PRODUCTS
CORPORATION

THIS DRAWING, WHICH CONTAINS PROPRIETARY INFORMATION, IS THE PROPERTY OF JAMESTOWN ADVANCED PRODUCTS CORPORATION. IT SHALL NOT BE REPRODUCED IN ANY MANNER NOR DISCLOSED TO THIRD PARTIES WITHOUT WRITTEN PERMISSION OF JAMESTOWN ADVANCED PRODUCTS CORPORATION.

DATE : 2-27-04

PRODUCT PART NUMBER : 11135, 37, 38 & 39
(-53 THRU -54)

REV. NO.

PRODUCT DESCRIPTION :
8' HANDICAPPED PLASTISOL PICNIC TABLE

2855 GIRTS ROAD
JAMESTOWN, NY 14701