

- Fire ring has an overall diameter of 31 5/8" x 11 1/4" high and is constructed of 3/16" thick steel (A569).
- Fire ring is constructed with a formed (not welded) 1" flange for superior strength.
- Grate is constructed from 1/2" dia. A36 steel bars located on 1 1/8" centers. The non-adjustable theft proof grate has a cooking area of 270 sq. inches. There are some extra bars welded to the grate on either side to prevent the building of fires when the grate is locked to the fire ring.
- Grate handle is constructed of a 5/8" dia. A36 steel bar with stay cool spring grips suitable for public use.
- Ring is mounted using spade anchors. The spade anchors permanently anchor the fire ring to the ground.
- A 3/8" chain, grade 30, is welded to the fire ring, and a locking bracket is welded to the grate. The purpose of the chain is to loop it through the bracket and lock it together using a padlock (supplied by customer).
- All joints are continuously welded.
- All exposed corners are chamfered for safety.
- Standard finish is a non-toxic black powder coat.
- Approximate weight = 125 lbs.

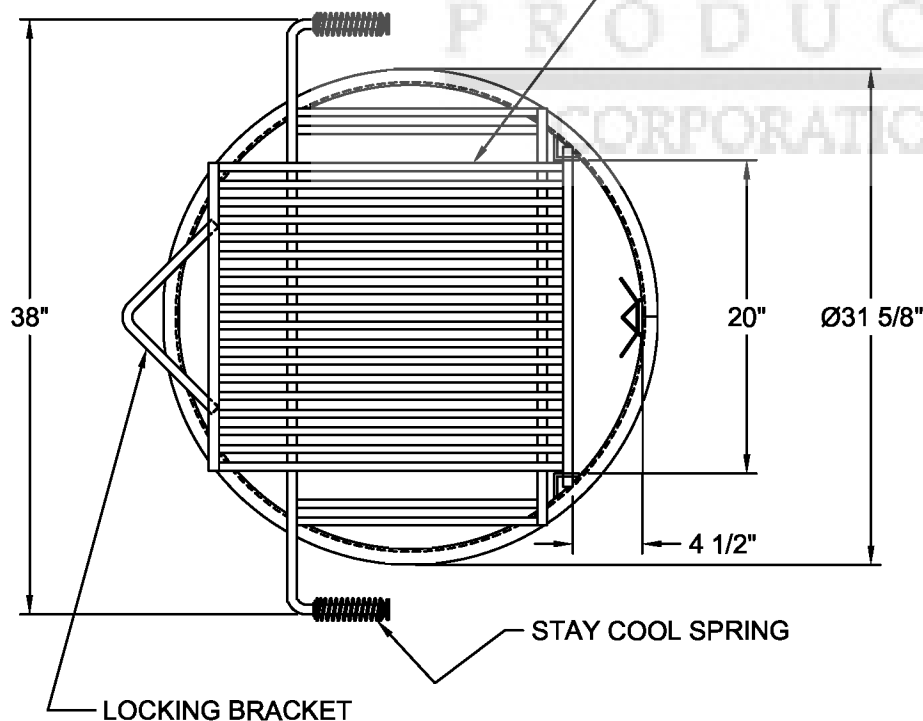
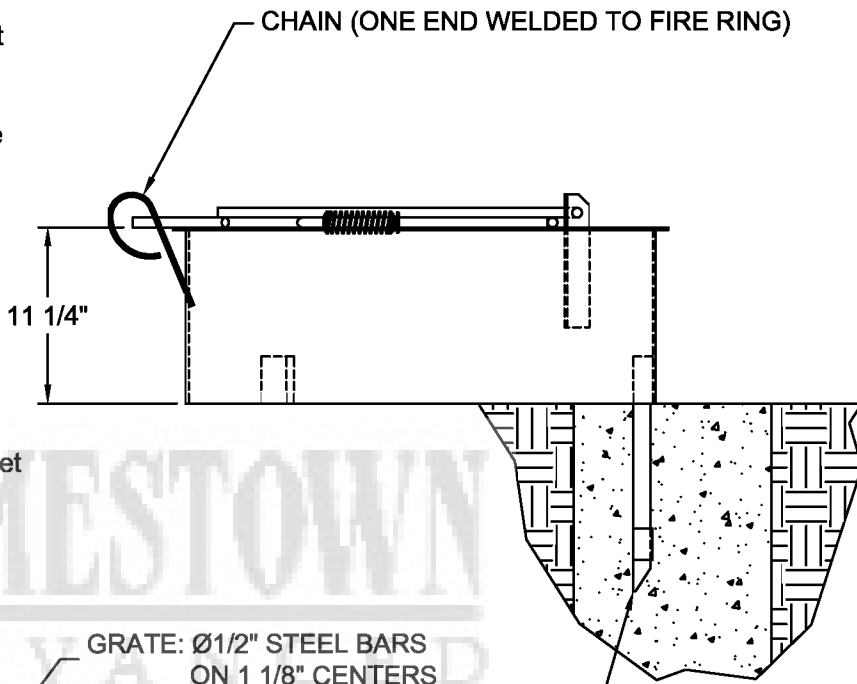

NOTE : CUSTOMER TO PROVIDE CONCRETE ( RECOMMENDED )

CUSTOMER APPROVAL :

DATE :

**JAMESTOWN**  
ADVANCED  
PRODUCTS  
CORPORATION

THIS DRAWING, WHICH CONTAINS PROPRIETARY INFORMATION, IS THE PROPERTY OF JAMESTOWN ADVANCED PRODUCTS CORPORATION. IT SHALL NOT BE REPRODUCED IN ANY MANNER NOR DISCLOSED TO THIRD PARTIES WITHOUT WRITTEN PERMISSION OF JAMESTOWN ADVANCED PRODUCTS CORPORATION.

DATE : 10-24-02

PRODUCT PART NUMBER : 11586-MOD

REV. NO.

PRODUCT DESCRIPTION :

Ø30" x 11 1/4" HIGH SINGLE FLANGE FIRE RING  
W/SPECIAL NON-ADJ. GRATE & LOCKING PROVISION

2855 GIRTS ROAD  
JAMESTOWN, NY 14701

PHONE 800-452-0639 -- FAX 716-483-5398 -- WWW.JAMESTOWNADVANCED.COM