

PART NO.	DESCRIPTION
12223	FIRE RING FOR NATIONAL FOREST SPECS

- Fire ring has an overall diameter of 26" x 22" high complete with drain/draft holes, and is constructed of 3/16" thick steel (A569).
- Grate is constructed from 1/2" dia. A36 steel bars located on 1 1/4" centers. The theft proof grate has a cooking area of 270 sq. inches. It is mounted on a swivel to allow for 360° rotation.
- All joints are continuously welded.
- All exposed corners are chamfered for safety.
- Standard finish is a non-toxic black powder coat.
- Approximate weight = 135 lbs.

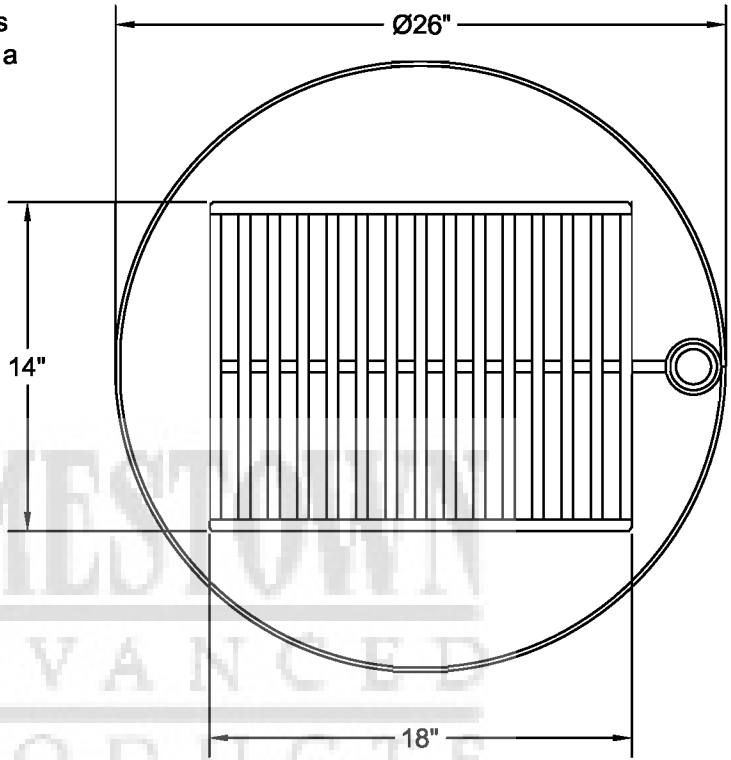

3/8" x 4" SLOT. 10 EQUALLY SPACED SLOTS AROUND THE RING PERIMETER.

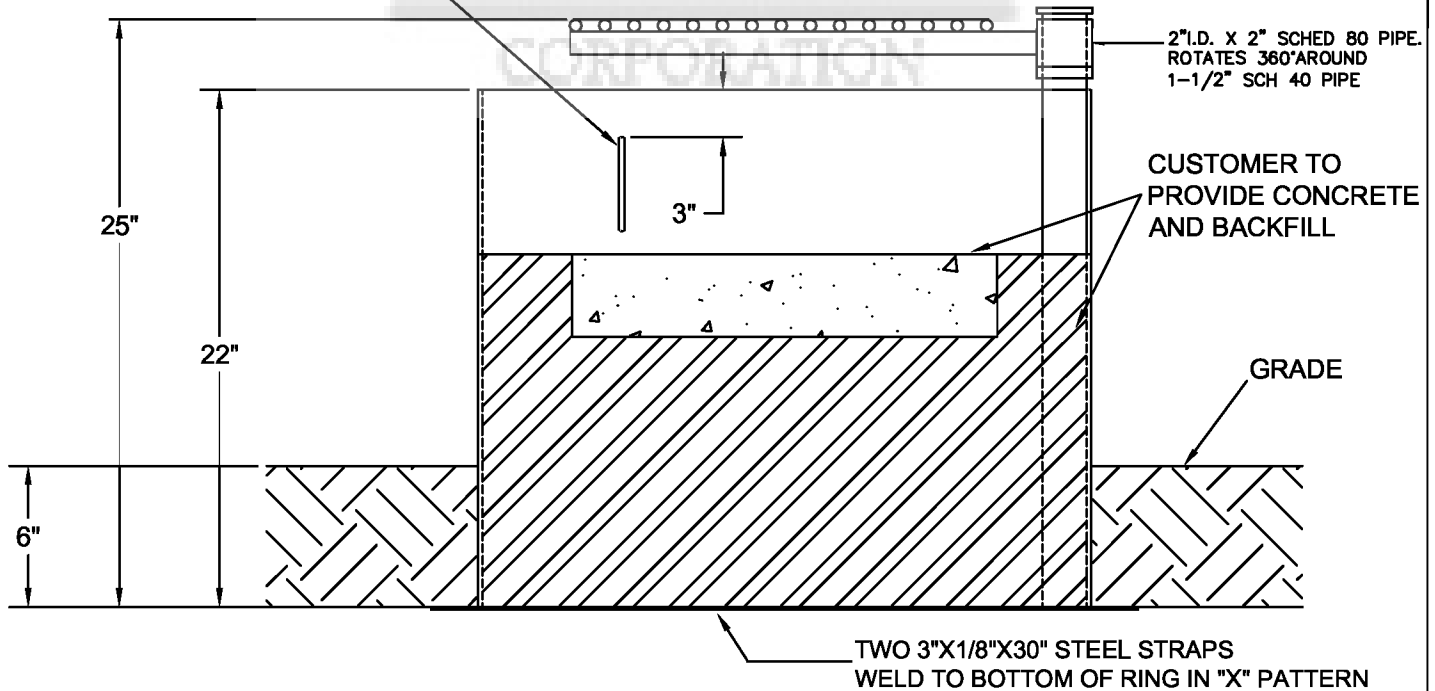

CUSTOMER APPROVAL :

DATE :

JAMESTOWN
ADVANCED
PRODUCTS
CORPORATION

THIS DRAWING, WHICH CONTAINS PROPRIETARY INFORMATION, IS THE PROPERTY OF JAMESTOWN ADVANCED PRODUCTS CORPORATION. IT SHALL NOT BE REPRODUCED IN ANY MANNER NOR DISCLOSED TO THIRD PARTIES WITHOUT WRITTEN PERMISSION OF JAMESTOWN ADVANCED PRODUCTS CORPORATION.

DATE : 9-11-03

PRODUCT PART NUMBER : 12223

REV. NO.

PRODUCT DESCRIPTION :
FIRE RING FOR NATIONAL FOREST SPECS

2855 GIRTS ROAD
JAMESTOWN, NY 14701